



**Electrolux**  
PROFESSIONAL

**High Productivity Cooking  
Touchline tilting braising pan, gas  
(98,861BTU), 45 gal (170 lt)**

ITEM # \_\_\_\_\_  
 MODEL # \_\_\_\_\_  
 NAME # \_\_\_\_\_  
 SIS # \_\_\_\_\_  
 AIA # \_\_\_\_\_



**587039 (PFET17GCWU)** Touchline tilting braising pan, gas (98,861BTU), 45gal capacity (170lt) - 120V/1p/60Hz

**Short Form Specification**

**Item No.** \_\_\_\_\_

AISI 304 stainless steel construction. GN compliant pan size; 0.7" (18mm) thick pan bottom 0.6" (15mm) mild steel and 0.1" (3mm) AISI 316 stainless steel. Insulated and counterbalanced lid. Motorized tilting with variable speed control. Pan can be tilted beyond 90° to completely empty the food. Robust multiple burners with electronic ignition and monitoring. Safety thermostat protects the pan from overheating. A precise, electronic control of pan bottom temperature ensures fast reaction and exact adherence to preselected cooking temperatures between 122 and 482°F (50 and 250°C). TOUCH control panel. SOFT function. IPX6 water resistant. Configuration: Free-standing or Standing against a wall. Installation options (not included): floor mounted on 8" (200mm) high feet or a plinth which can be either steel or masonry construction.

**Main Features**

- Pan size is GN compliant.
- Temperature sensors provides efficient temperature control: the power is supplied as and when required to keep the set temperature value without exceeding it.
- Optimum heat distribution in the food provides best cooking results in terms of taste, color and consistency and in terms of vitamin preserving.
- Easy to clean cooking surface due to large-radius edges and corners.
- Motorized, variable pan tilting with "SOFT STOP". Tilting and pouring speeds can be precisely adjusted. Pan can be tilted over 90° to facilitate pouring and cleaning operations.
- IPX6 water resistant.
- Built in temperature sensor to precisely control the cooking process.
- No overshooting of cooking temperatures, fast reaction.
- USB connection to easily update the software, upload/download recipes and download HACCP data.
- Multifunctional cooking appliance used for roasting, pot-roasting, braising, simmering, boiling and steaming.
- Connectivity ready for real time access to connected appliances from remote and data monitoring (requires optional accessory - contact the Company for more details).

**Construction**

- External panelling and internal frame made of 1.4301 (AISI 304) stainless steel.
- Double-lined insulated lid in 1.4301 (AISI 304) stainless steel mounted on the cross beam of the unit, counterbalanced by a hinge that remains open in all positions.
- Gas appliance has robust multiple burners with electronic ignition and monitoring for a safer operation. Operation with natural gas and LPG (on request).
- Water mixing tap is available as optional accessory to make water filling and pan cleaning easier.
- Minimised presence of narrow gaps for easier cleaning of the sides to meet the highest hygiene standards.
- Heatproof handle with non-slip surface.
- Front-mounted inclined led "TOUCH" control panel with recessed deep drawn casing, features self-explanatory display functions which guide operator throughout the cooking process: simultaneous display of actual and set temperature as well as set

**APPROVAL:** \_\_\_\_\_



cooking time and remaining cooking time; real time clock; "SOFT" control for gentle heating up for delicate food; 9 power simmering levels from gentle to heavy boiling; timer for deferred start; error display for quick trouble-shooting.

- Possibility to store recipes in single or multiphase cooking process, with different temperature settings.
- Can be prearranged for energy optimisation or external surveillance systems (optional).
- 98% recyclable by weight; packaging material free of toxic substances.
- Multipurpose non-stick cooking surface in 0.75" (18 mm) thick compound: 0.1" (3 mm) shot-blasted 1.4404 (AISI 316L) stainless steel surface, seamlessly welded to the mild steel bottom.
- [NOT TRANSLATED]
- [NOT TRANSLATED]
- [NOT TRANSLATED]

### Sustainability



- High-quality thermal insulation of the pan saves energy and keeps operating ambient temperature low.

### Optional Accessories

- Perforated container with handles, PNC 910211   
height 4" (102mm)
- Perforated container with handles, PNC 910212   
height 6" (152mm)
- Perforated container with handles, PNC 911673   
height 8" (203mm)
- Left cover plate and mixing faucet PNC 911819   
for kettle (587040), and all braising  
pans (587037, 587039, 587031,  
587035, 587027, 587028, 587021,  
and 587025)
- Suspension frame for Non- PNC 912709   
Pressurized Tilting Braising Pans - 2  
needed for 24 gallon units (587031,  
587037) - 3 needed for 45 gallon  
units (587035, 587039)
- Spray gun for tilting units, height PNC 912776   
27-1/2" (698.5mm) - factory fitted
- SCRAPER WITHOUT HANDLE PNC 913431   
(PFEX/PUEX)
- - NOT TRANSLATED - PNC 913432
- 4 flanged feet, 2", for prothermetic PNC 913438   
units (kettles, braising pans &  
pressure braising pans)

# High Productivity Cooking Touchline tilting braising pan, gas (98,861BTU), 45 gal (170 lt)

Front

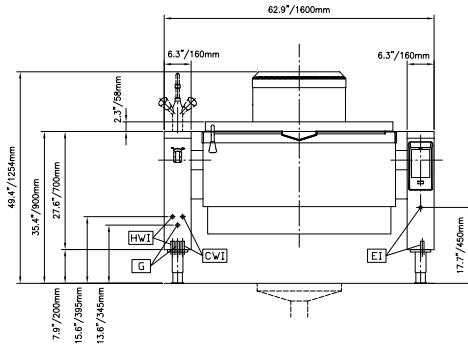

Side

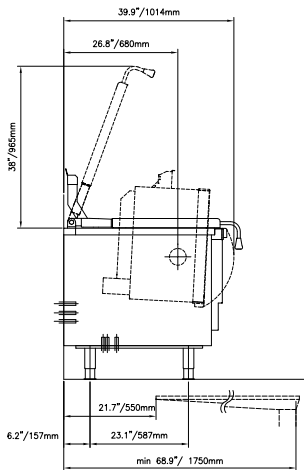

CWI = Cold Water inlet

EI = Electrical connection

G = Gas connection

Top

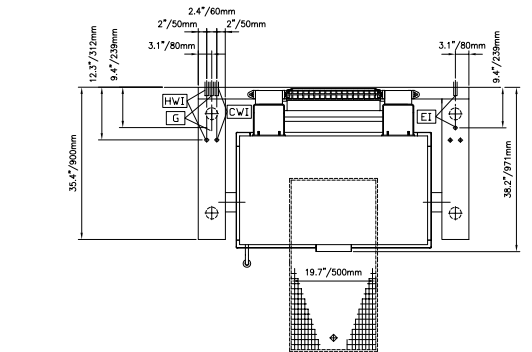

## Electric

### Supply voltage:

587039 (PFET17GCWU) 120 V/1 ph/60 Hz

### Total Watts:

0.2 kW

## Gas

### Gas Power:

98948 Btu/hr (29 kW)

### Gas Type Option:

Propane

### Gas Inlet:

3/4"

## Water:

### Pressure:

29-87 psi (2-6 bar)

### Incoming Cold/hot Water line size:

1/2"

## Installation:

FS on concrete base; FS on feet; On base; Standing against wall

### Type of installation:

## Key Information:

### Configuration:

Rectangular; Tilting

### Working Temperature MIN:

122 °F (50 °C)

### Working Temperature MAX:

482 °F (250 °C)

### External dimensions, Width:

63 " (1600 mm)

### External dimensions, Depth:

35 7/16" (900 mm)

### External dimensions, Height:

27 9/16" (700 mm)

### Net weight:

661 lbs (300 kg)

### Shipping width:

66 15/16" (1700 mm)

### Shipping depth:

48 13/16" (1240 mm)

### Shipping height:

59 1/16" (1500 mm)

### Shipping weight:

1036 lbs (470 kg)

### Shipping volume:

 111.65 ft<sup>3</sup> (3.16 m<sup>3</sup>)

### Heating type:

Direct

### Tilting mechanism:

Automatic